

FRONT GEOMETRY

- RIDE HEIGHT _____
- DROOP _____
- TOE IN/OUT _____
- CASTER _____
- STABILIZER _____
- CAMBER _____
- NOTES _____

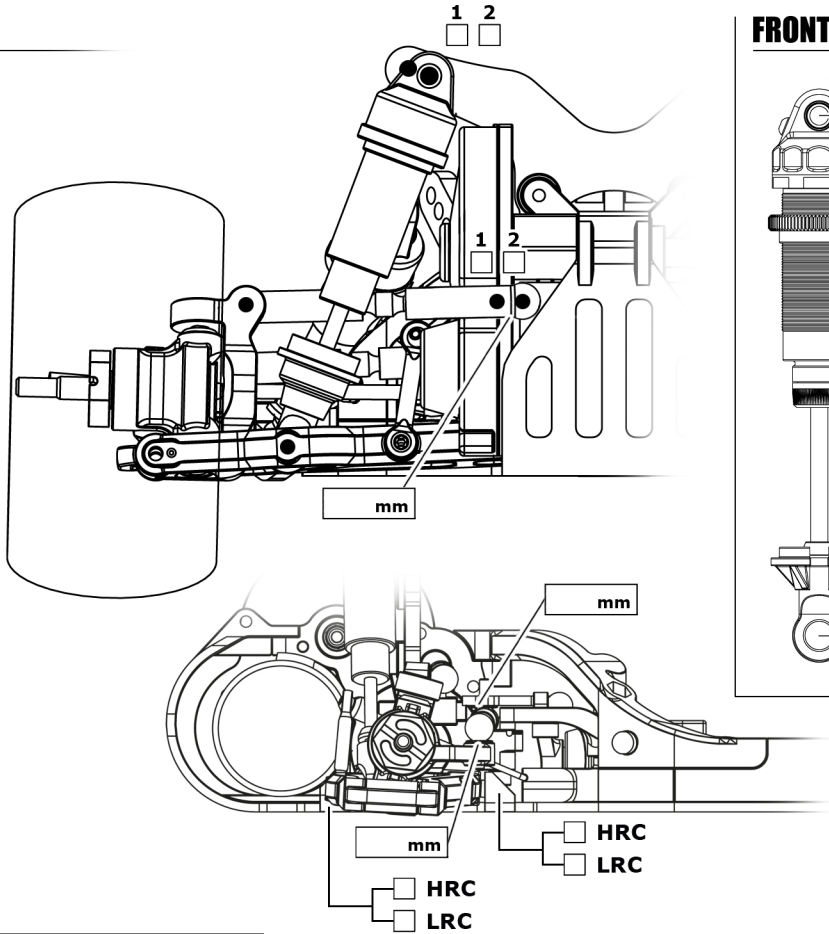

FRONT SHOCKS

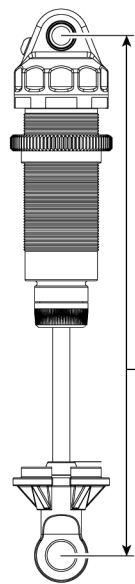

- DAMPER TYPE _____
- SPRINGS _____
- OIL _____
- PISTONS _____
- REBOUND _____
- LENGTH _____
- NOTES _____

REAR GEOMETRY

- RIDE HEIGHT _____
- DROOP _____
- TOE IN/OUT _____
- STABILIZER _____
- CAMBER _____

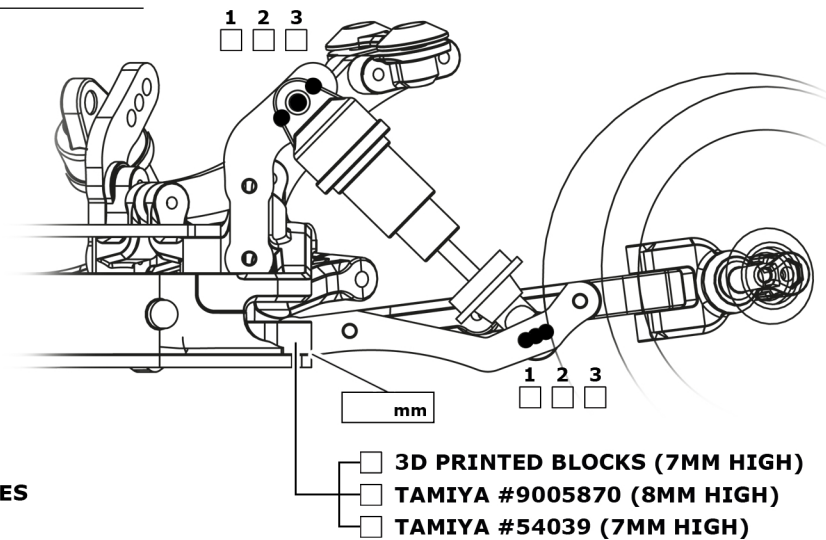

NOTES _____

REAR SHOCKS

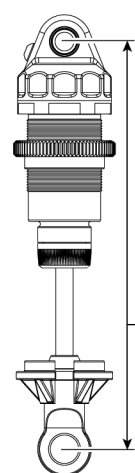

- DAMPER TYPE _____
- SPRINGS _____
- OIL _____
- PISTONS _____
- REBOUND _____
- LENGTH _____
- NOTES _____

CHASSIS+ELECTRONICS

DIFFERENTIAL
_____SLIPPER CLUTCH
_____MOTOR
_____SPUR GEAR / PINION GEAR
_____ESC TYPE
_____PUNCH & BOOST SETTINGS
_____BRAKE & DRAG BRAKE SETTINGS
_____SERVO
_____BATTERY & LOCATION
_____WING
_____WEIGHT
_____WEIGHT BALANCE FRONT/REAR
_____WIDTH FRONT & REAR
_____NOTES

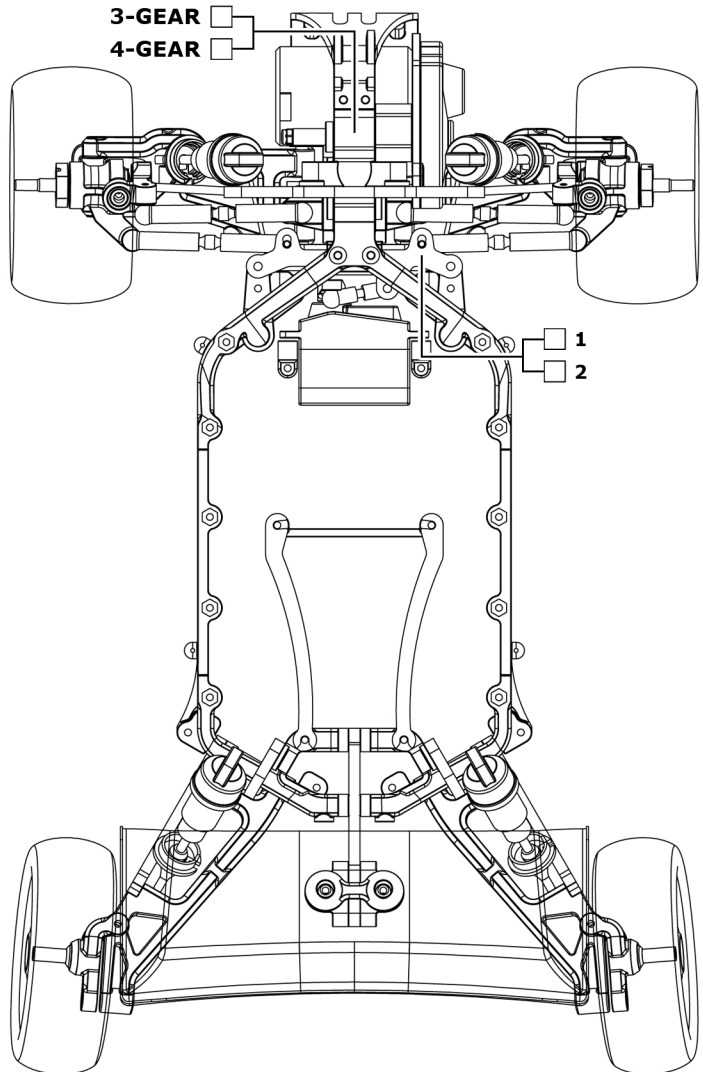
_____

FRONT TIRES

BRAND
_____TREAD+COMPOUND
_____INSERT
_____RIMS
_____NOTES

REAR TIRES

BRAND
_____TREAD+COMPOUND
_____INSERT
_____RIMS
_____NOTES

SETUP COMMENTS

